

3D SOLUTION RECOVERY SYSTEM

SINGLE BUTTON OPERATION

SKU: 68-2500W-DWS

1



LOAD

2



LATCH

3



PUSH



YOU'RE DONE!

You'll have clean solvent after the machine automatically turns off.



Recycling-it's about savings.

Recycling of Hazardous Waste Benefits Everyone

HAZARDOUS WASTE

There are only two legal ways to dispose of these hazardous wastes:

1. For less than 100 kilograms of waste per month, obtain an EPA identification number as a small quantity generator and pay a registered transporter to haul the waste to an approved recycling facility or other type of approved facility ... or
2. Recycle the used solvent on site for future reuse.

Hazardous waste generators have a "cradle to grave" responsibility for safe disposal of hazardous wastes. Federal law says the generator is responsible for the waste he creates, regardless of who hauls it away or where it is stored. His name is on the barrel and if it is spilled or otherwise causes pollution, he is responsible for the cleanup. Forever!

Of course to dispose of hazardous wastes in any unlawful way is just foolhardy and a good way to risk heavy cleanup costs, stiff fines and possible jail time.

THE Recovery METHOD

The 3D Solution Recovery System is a Refrigeration Machine Distiller-Reclaimer, it processes 5 gallons or less per batch. A standard 5 gallon metal bucket of waste is placed in the chamber. Waste solvents are vaporized and re-condensed, making the solvent reusable. The vapors expand in the chamber, displacing air. The vapors, being heavier than air, then fall through a refrigerated heat exchanger, condense and gravity flow out into the clean solvent receiving vessel. The waste stays behind in the cooking bucket within the chamber.

The vaporizing chamber is built to pressure cooker specifications. Although the unit operates at atmospheric pressure a safety pressure relief valve is installed in the lid. Metal to metal machined surfaces seal the chamber and its' lid, which is held fast during processing with 6 bakelite wing nut assemblies.

The vapor tubes and the outlet tubes are of TFE Teflon . The evaporator (condensing chamber) is stainless steel. The lightweight aluminum stand is provided with floor mount capabilities. The 3D Solution Recovery System is covered by a one year limited warranty. The 3D Solution Recovery System is for use in commercial and industrial applications only by trained personnel. Strict adherence to cautious handling of hazardous materials must be maintained always. For location, wiring, and operating instructions, refer to the owners manual.

PITFALLS To AVOID

As with most products, there are some pitfalls to avoid. Only knowledgeable persons should be allowed to operate the 3D Solution Recovery System.

- Never process unidentified compounds.
- Avoid the processing of wastes containing acids.
- Do not process wastes containing Nitrocellulose or Cellulose Nitrate (found in many lacquers and inks) or other reactive materials under any circumstance.
- Know what you are processing and check material safety data sheets for the waste contaminants as well as for the solvent to be recycled for compatibility before processing.

ELECTRICAL

Because of the small batch size, the rate of processing, air movement through the condensing unit and the heavier than air qualities of the vapors produced, under normal operating conditions, the minimum concentration of gases or vapors necessary to define Class 1, Division 1 area are not present.

The 3D Solution Recovery System has been investigated for use in normal, non-hazardous locations and Listed by Underwriters

The 1997 Uniform Fire Code, Volume 1, 10th Edition, Article 79 section 7903.4, states:

7903.41 General. Solvent distillation units used to recycle Class I, II or III-A liquids having a distillation chamber capacity of 60 gallons (227.1L) or less shall be listed, labeled and installed in accordance with Table 7903.4 and nationally recognized standards. See Article 90, standard u.1.17.

ARTICLE 90 - STANDARDS

u.1. UNDERWRITERS LABORATORIES INC.
333 Pfingsten Road, Northbrook IL 60062
UL STANDARDS

u.1.17. UL 2208 Standard for Solvent Distillation Units

Laboratories Inc. as compliant with UL 2208 Standard for Solvent Distillation Units.

The process is continuously monitored by an electronic logic printed circuit board. Automatic shut down is commenced in the unlikely event of an over heat situation. These safeguards not only shut off the unit, but disable it until a service representative can evaluate the problem and help with repairs.

EASY TO OPERATE

1



LOAD

Your used solvent. We recommend loading your used solvent in a bucket outside of the 3D Solution Recovery System - to avoid any spillage.



2



LATCH

Metal to metal machined surfaces seal the chamber and its' lid, which is held fast during processing with 6 bakelite wing nut assemblies.

3



PUSH

The On button which will illuminate red when the machine is processing solvents. Different variables determine the amount of processing time.

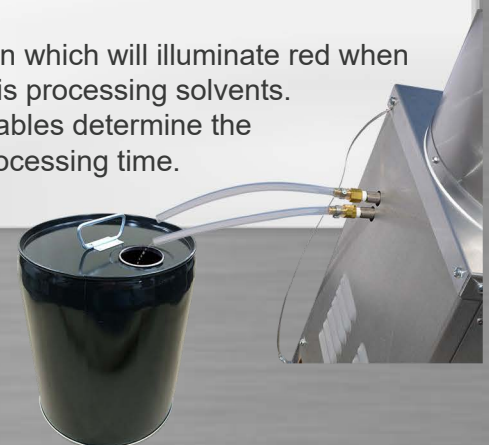

FRONT VIEW

POT COVER LID
Unique lid design prevents vapors from escaping and eliminates the need for costly gaskets.

VAPORIZING CHAMBER
Built to pressure cooker specifications.

POWER LIGHT
Red light indicates when machine is plugged in.

LIGHTWEIGHT ALUMINUM STAND
Designed to mount to the floor.

BAKELITE HANDLE
BAKELITE WING KNOB
Durable and made to withstand high temperatures.

GUTTER
Protects the control panel from spillage.

READY LIGHT
Green light indicates when solvent has been fully processed & when you can remove the lid & load in your next batch.

ON / OFF BUTTON
The red switch will be illuminated when the machine is working on processing solvents.

MOUNTING HOLES
Select a well ventilated location out of direct sunlight, under cover and away from any other source of heat, then you can safely attach to the floor.



SIDE 2 - ACCESS PANEL

LOUVERS
Allows for proper ventilation.

ACCESS PANEL
This is the side to open to get to internal parts.

SERIAL NUMBER
Provide to customer service when calling in.

UL LISTED
Compliant with UL 2208 Standard for Solvent Distillation Units, for use in a normal location.



SIDE 3 - JUNCTION BOX



VAPORIZING CHAMBER ACCESS PANEL

Access for high temp monitoring sensors.

MULTI-PORT CERTIFIED JUNCTION BOX

Protects wires from exposure.

CONDENSING FINS

Be sure that debris is not allowed to restrict air flow.

BACK VIEW - OUTLET TUBES



EXTERNAL SAFETY GROUND STRAP

Helps ground the unit to solvent.

SOLVENT OUTLET TUBES

Made of TFE Teflon®, clean solvent pours out, be sure to put a bucket here to catch all of your savings.

Features

UL LISTED

The 3D Solution Recovery System is the first (as of 11/04/97 the only) UL Listed Solvent Recycler in the world.

MEETS UL 2208

UL 2208, Standard for Solvent Distillation Units is the US National Standard. 3D Solution Recovery System is certified by UL to meet the requirements of UL 2208.

CURRENT CODES

1997 Uniform Fire Code requires that a Solvent Recycler be listed by a nationally recognized third party testing agency and that it be certified by the testing agency to meet the requirements of UL 2208 Standard for Solvent Distillation Units.

COMPLIES WITH UL 2208 FOR USE IN ORDINARY NON-HAZARDOUS LOCATIONS

According to the Standard and Codes, a Solvent Distillation Unit complies for use in non-hazardous areas or it doesn't and must be put in either an Class I, Division 2 or Class I, Division 1 hazardous location. The 3D Solution Recovery System complies for use in non-hazardous locations.

NO EXPENSIVE SEALS OR GASKETS TO REPLACE

The design doesn't require the \$100.00 to \$300.00 annual expense for replacement seals, o-rings or gaskets.

HASSLE FREE

It couldn't be more simple. Load the unit with dirty solvent, 5 gallon bucket and all. Replace the lid. Press the button.

SINGLE BUTTON OPERATION

What more can we say?

RELIABLE

Follow the simple maintenance routine, for years of trouble free operation. We have many units in the field having completed their twentieth year and more.

EFFICIENT REFRIGERATION CONDENSED

We're the only one we know of that uses refrigeration to condense. The alternatives are: forced air - not totally efficient in warm climates or water cooled - wastes lots of water, messy and special consideration must be given to plumbing, water storage, water treatment and waste water disposal.

OZONE SAFE HFC-134a REFRIGERANT

Big brother made us do it, but it turned out for the best. We were able to get a larger horsepower unit to fit the same R-12 frame and it is more efficient than the old method.

SELF MONITORING

3D Solution Recovery System regulates temperature, engages condensing system, oversees built in safety fail-safes, initiates cool down and shuts off. All automatic.

AUTO SHUTDOWN

You go about your business... 3D Solution Recovery System knows when to shut off, even if you've given it your worst case mess. Solvents only, please - no water or water base.

PROCESSING BAGS OPTIONAL

We personally like the convenience of 3D Solution Recovery System processing bags but they are optional.

110-120 VOLTS

Easy to find a home, no special 240 volt wiring.

NO WATER HOOKUPS

This goes back to Hassle Free. Water cooled units - waste lots of water, are messy and special consideration must be given to plumbing, water storage, water treatment and waste water disposal.

MICRO CONTROL LOGIC

This time tested, rugged circuitry makes the operation simple.

SAFETY FAILSAFE & SHUTDOWNS

If something is unusual the control simply shuts it down.

MADE IN USA

It's where we live, work, and play.

FULL 1 YEAR LIMITED WARRANTY

3D Solution Recovery System Specs

Width	16 inches
Depth	16 inches
Height	44 inches
Net Weight	110 lbs.
Voltage	110/120VAC
Current	11 amps
Heater	1050 Watts
Condensing System	Refrigeration
Evap Temp Rate	Low
Refrigerant	Ozone Safe HFC-134a 0.16kg
Evap Temp Range	0°F to +15°F
Cap Tube	96" x .042" ID
Operating Pressure	Atmosphere
Warmup Time	Approx. 90 min.
Capacity	5 US Gallons
Electronics	Micro-Linear Logic
Safety Limits	Heating Vessel Evaporator
UL Listed	UL Standard 2208

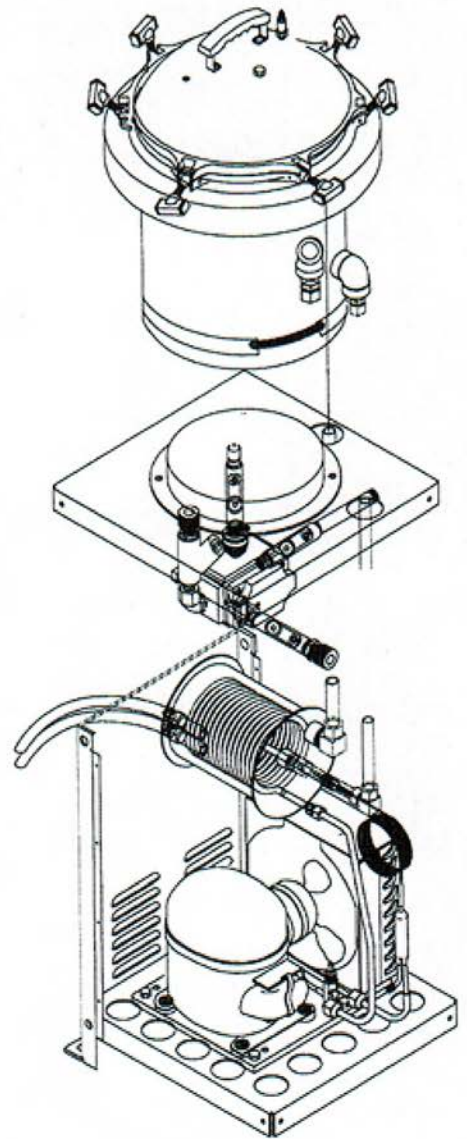

Required Clearances - 16" Ventilation Clearance

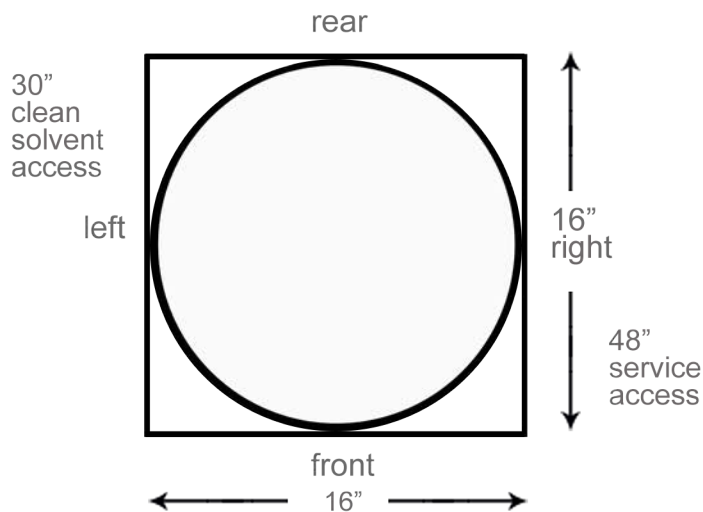

Locate in a level, well ventilated, under cover area. Out of grinding, welding and smoking area.



Recycling of Hazardous Wastes Benefits All!



ROMANOFF
INTERNATIONAL SUPPLY CORPORATION

Romanoff International Supply Corp
9 Deforest St, Amityville NY, 11701 USA
Phone: +1-800-221-7448
Email: sales@romanoff.com
Website: www.romanoff.com